

ITEM NO.	PART NUMBER	DESCRIPTION	QTY
29	HX-SHCS 0.375-16x075x0.75-C	1/2-13 x 2" HHCS Grade 5	4
30	HHNUT 1.0000-12-B-N	1"-14 Nylock Thin Nut	1
31	SSHDOGSKT 0.25-20x1-HX-N	1/4-20 x 1-1/2" Set Screw	4
32	HX-SHCS 0.25-20x0.75x0.75-N	1/4-20 X 3/4" SHCS	1
33	HX-SHCS 0.25-20x0.5x0.5-C	1/4-20 X 1/2" SHCS	2
34	HTNUT 0.6250-11-D-N	5/8-11 Nylock Nut	4
35	HJNUT 0.2500-20-D-N	1/4-20 Jam Nut	4
36	HX-SHCS 0.375-16x1.5x1.5	3/8-16 x 1-1/2" SHCS	4
37	1UY18	1/2-13 x 3" HHCS	2
38	1AJ55	1/2-20 x 1-1/2" Set Screw	4
39	1JY49	1/2-20 Jam Nut	4
40	FW 1.0	1" Flat Washer	1
41	FW 0.5	1/2" Flat Washer	6
42	91259A845	5/8-11 x 2-1/2" SHSB	4
43	HX-SHCS 0.3125-24x1.25x1.25-C	5/16-18 x 1-1/4" SHCS	1
44	HNUT 0.3125-18-D-C	3/8-16 Nylock Nut	4
45	SHSSCREW 0.375x2.5-C	3/8 x 2-1/2" SHSB	1
46	400-598	Vibration Damping Mount	4
47	Urethane Strip	Urethane Strip	2
48	LOCKNUT .250-20	1/4-20 Locknut	4

ITEM NO.	PART NUMBER	DESCRIPTION	QTY
1	4200-206	Driveshaft	1
2	4200-219	Connecting Bar	1
3	4200-207	Fly Wheel	1
4	4200-208	Driveshaft Key	2
5	4200-209	Crank Pin	1
6	4200-210	Crank Pin Spacer	1
7	4200-215	Drive Pulley Key	1
8	4200-506	Small Pulley, Driver	1
9	4200-521	Motor (Leeson # 116757)	1
10	4200-511	Large Pulley, Driven	1
11	4200-518	3/8 UBolt - Spring Shackle	2
12	4200-514	Needle Bearing/Race	1
13	4200-512	Ball Bearing Pillow Block	2
14	4200-513	Collar Bushing	1
15	4200-285	Die Clamp	4
16	4200-522	43" Drive Belt	1
17	4200-281	3/8" Anvil Shim	4
18	4200-283	1/8" Anvil Shim	1
19	4200-282	1/4" Anvil Shim	1
20	4200-280	Anvil Base	1
21	4200-201	Dovetail Slide	1
22	4200-202	Dovetail Gib	1
23	4200-203	PH Ram	1
24	4200-216	Link	4
25	4200-508	Leaf Spring Assembly	1
26	200-529	Foot Pedal, Variable Speed	1
27	400-597	VARIABLE DRIVE (SIMULATED) KBAC 27D	1
28	4200-505	Conveyor Strap	1

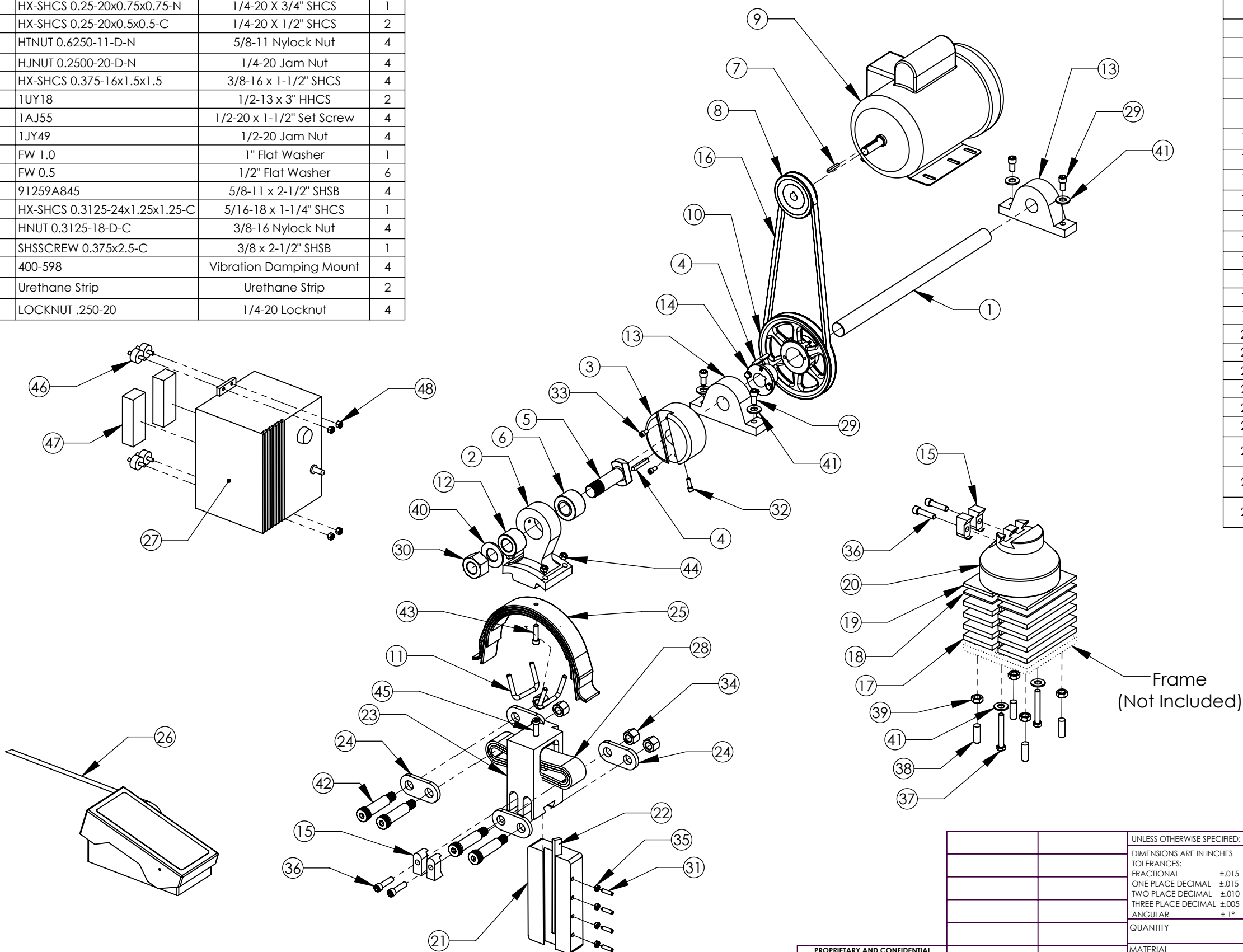

PROPRIETARY AND CONFIDENTIAL
 THE INFORMATION CONTAINED IN THIS DRAWING IS THE SOLE PROPERTY OF MITTLER BROS. MACHINE & TOOL. ANY REPRODUCTION IN PART OR AS A WHOLE WITHOUT THE WRITTEN PERMISSION OF MITTLER BROS. MACHINE & TOOL IS PROHIBITED.

UNLESS OTHERWISE SPECIFIED:		NAME	DATE
DIMENSIONS ARE IN INCHES		DRAWN	MSA 7/13/2017
TOLERANCES:		CHECKED	
FRACTIONAL	±.015	ENG APPR.	
ONE PLACE DECIMAL	±.015	MFG APPR.	
TWO PLACE DECIMAL	±.010	Q.A.	
THREE PLACE DECIMAL	±.005		
ANGULAR	± 1°		
QUANTITY			
MATERIAL	FINISH		
	LENGTH		
NEXT ASSY	USED ON	COMMENTS	
APPLICATION	DO NOT SCALE DRAWING		

M3 MITTLER BROS. MACHINE & TOOL
 10 Cooperative Way, Wright City MO. 63390
 (636)745-7757 Fax (636)745-2874

TITLE: Powerhammer Kit
Variable Speed

SIZE DWG. NO. REV
B 4200-200-VS

SCALE: 1:8 WEIGHT: SHEET 1 OF 2

8 7 6 5 4 3 2 1

D
C
B
A

D
C
B
A

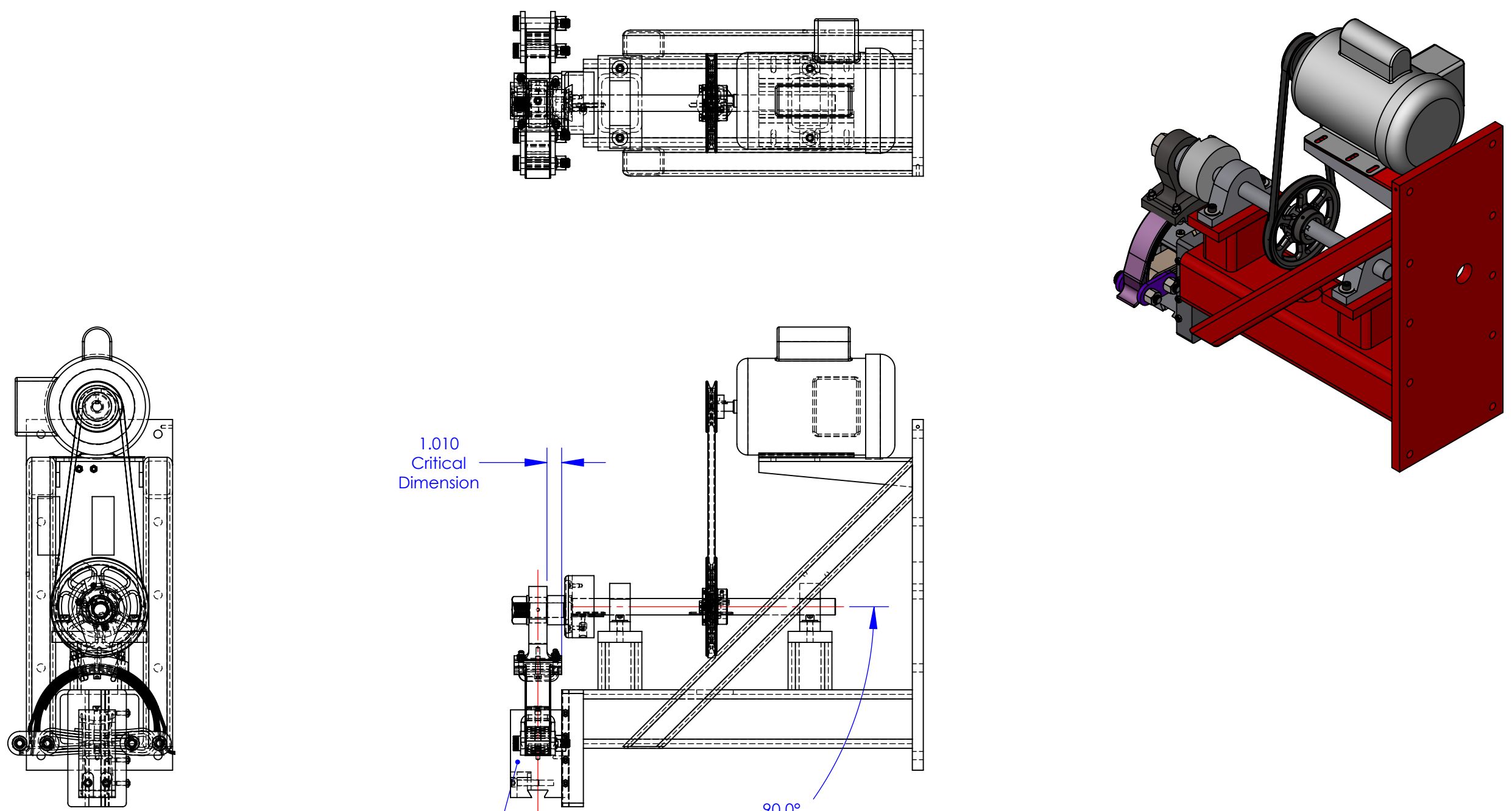

1.010
Critical
Dimension

90.0°
True alignment of axis
in all 3 planes is CRITICAL
for reliable performance

Lubricate with 60%
Molybdenum Disulfide Grease
before operation

PROPRIETARY AND CONFIDENTIAL
THE INFORMATION CONTAINED IN THIS
DRAWING IS THE SOLE PROPERTY OF
MITTLER BROS. MACHINE & TOOL. ANY
REPRODUCTION IN PART OR AS A WHOLE
WITHOUT THE WRITTEN PERMISSION OF
MITTLER BROS. MACHINE & TOOL IS
PROHIBITED.

		UNLESS OTHERWISE SPECIFIED:		NAME	DATE
		DIMENSIONS ARE IN INCHES		DRAWN	MSA 7/27/2017
		TOLERANCES:		CHECKED	
		FRACTIONAL ±.015		ENG APPR.	
		ONE PLACE DECIMAL ±.015		MFG APPR.	
		TWO PLACE DECIMAL ±.010		Q.A.	
		THREE PLACE DECIMAL ±.005			
		ANGULAR ± 1°			
	QUANTITY				
	MATERIAL		FINISH		
			LENGTH		
NEXT ASSY	USED ON		COMMENTS		
APPLICATION		DO NOT SCALE DRAWING			

MB MITTLER BROS. MACHINE & TOOL
10 Cooperative Way, Wright City MO. 63390
(636)745-7757 Fax (636)745-2874

TITLE:
PH Kit/Upper Arm Assmy

SIZE	DWG. NO.	REV
B	4200-200-VS	

SCALE: 1:8 WEIGHT: SHEET 2 OF 2

8 7 6 5 4 3 2 1